

- **GROUP WITH SUPPORTS AND DUST CUP CYLINDERS** for short movements.
- Use with single screw or double screw in parallel with single drive.
- Supports in nitrided steel with axial/radial bearings and bronze flange nut on trapezoidal screw. Supports ready for rubber protective covers.

Group **E/DXA+LXY** (first diagram on the side) with short screw and dust protection, allows the regulation of axial play and is mostly used horizontally, however it can also be used vertically/obliquely after prior risk assessment relative to the specific application. The system allows the control of the maximum wear of the nuts, **tolerable up to a 1/4 of a pass**, and helps to provide an adequate protection for the machine by limiting any eventual risks due to nuts breaking. Please find on page 154 the system for axial play adjustment and for wear control together with the information plate we supply to apply to the machinery. **If greater vertical safety is required use the Excellent Safety Groups.** For vertical use with gearmotor (or other) above the arrangement of the supports is in the sequence shown in the diagram. In particular cases in which the gearmotor (or other) is positioned below the mobile supports have to be flipped 180° with LX above and LY below and checking that the arrows indicating the force of gravity are facing downwards.

- The guarantees of functionality and safety are determined by the proper use of the group together with perfect fitting on the machinery with the tabs inserted and the engraved arrows facing the same direction and, if used for vertical/oblique movements, they must face downwards.
- The **E/DXA+LX** Group (second diagram on the side) is only used for horizontal applications with short screw where axial play adjustment is not necessary. All of the Excellent Groups can be purchased pre-assembled, with the supports inserted on the trapezoidal screw, in that for mounting on the Manoeuvring Unit requires no dismantling, fitting the Group to the machine as shown on the **Excellent application diagram 2/A** on page 159.

Our Groups are ready for the fitting of accessories such as gearmotors, handwheels, position indicators and others. These items defined as "complementary accessories" are normally available from us, preselected according to the specially machined screw terminal, preassembled together with the supports that form the Group itself (Group ready for rubber protective covers and complementary accessories detailed on page 265).

For the correct use of this Group we also recommend reading the technical instructions on pages 125-127.

- **Indicative diagram of Manoeuvring Unit using "Excellent Steel LXY" Group with "short" trapezoidal screw and axial play adjustment.**

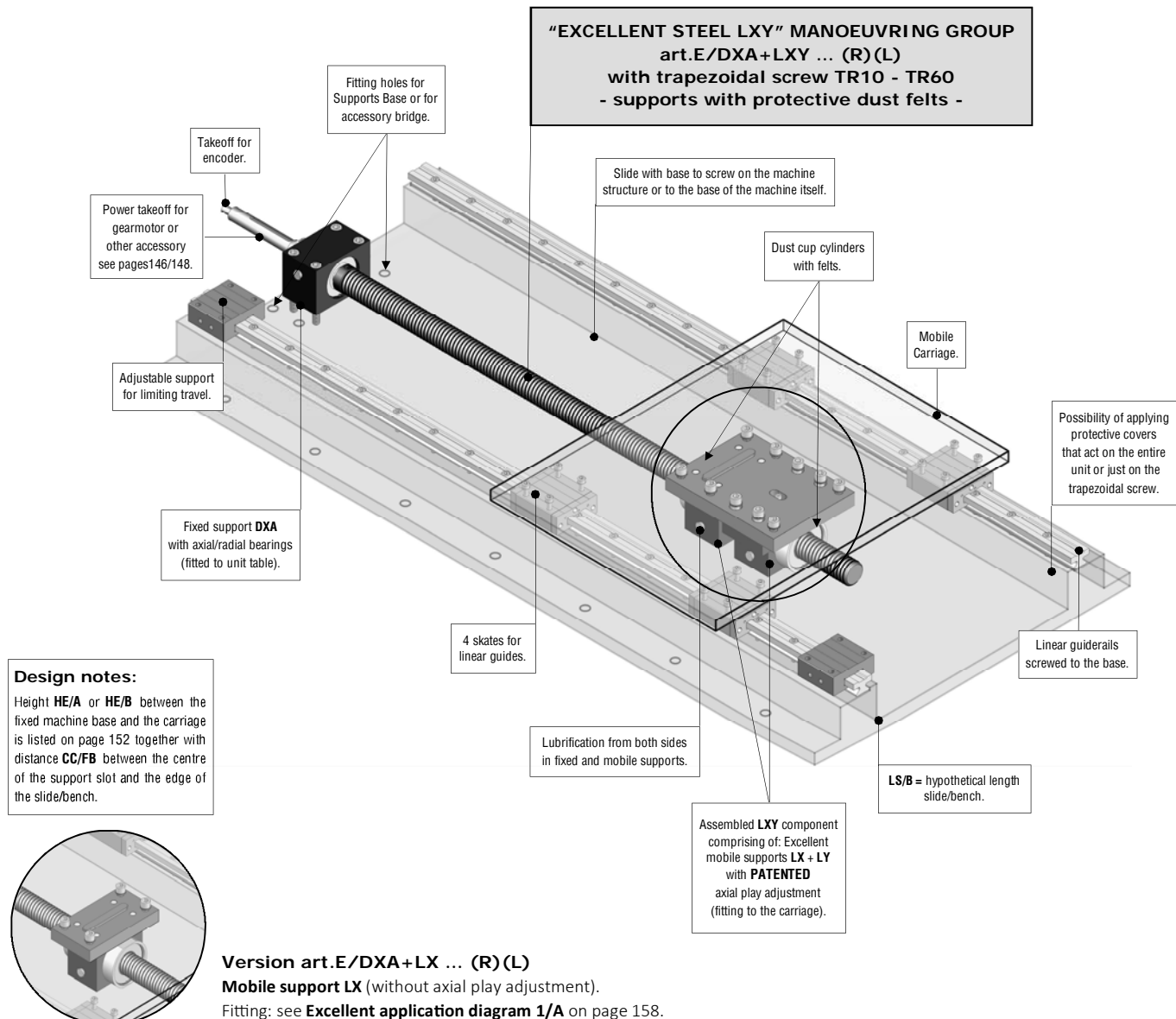

Group with right threaded components available from stock; with left threaded components made to order.

