

art.DXO/A

FIXED SUPPORTS mod.10/40 in anodized aluminium alloy with axial/radial bearings and accessories.

Assembled DXO/A support.

DXO/A Support - exploded diagram.

Standard fitting on the machine with or without Supports Base.

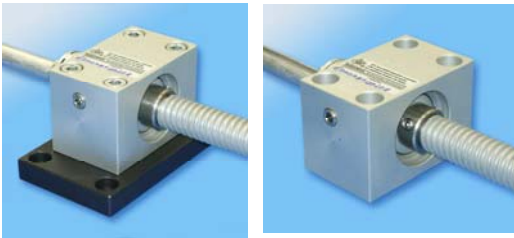

Fitting below machine with or without Supports Base.

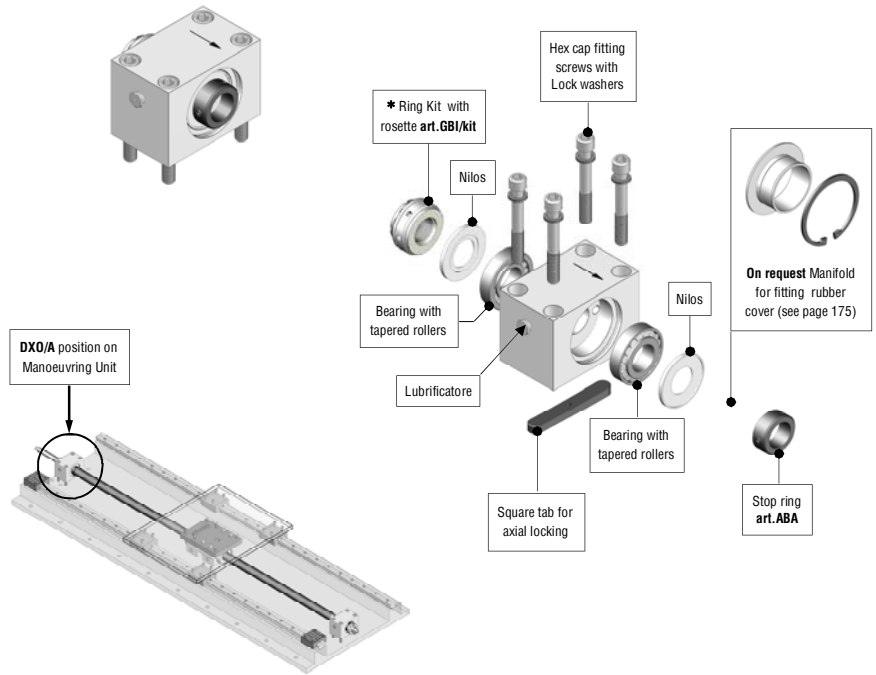
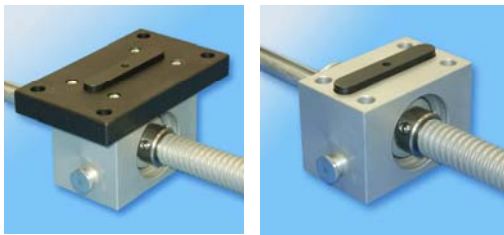

– Support DXO/A ready for fitting to the machine. Available if necessary, as shown in the two photos, with Supports Base art.BD LXR (please see page 144), and request they can be made in aluminium alloy.

– Accessory support bracket art.SMA please see page 146

\* Alternatively, for particular technical requirements for manual/horizontal movements, the DXO/A support is available with self-locking ring GHA (please see page 51).

– Complete diagrams showing how to fit to the machine are on pages 158-161.

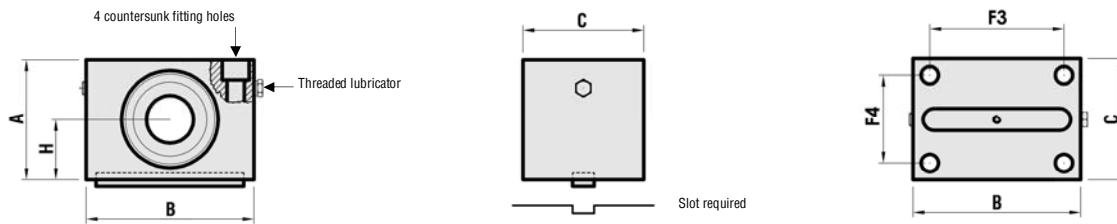

– C = Nett size of the support excluding accessories and possible Manifold for protective cover.

– Approximate weight with accessories and fitting bolts, excluding Supports Base BD LXR.

MODELS	CODE	ARTICLE	A	B	C	H	Ø Internal of bearings	F3	F4	Hex. Cap screws for fitting	Slot required for fitting	Threaded Lubricator	WEIGHT Kg
mod. 10	301SF310	DXO/A 10	34	55	30	17,5	10 (8)	40	17	M6x40	Ø5x42x3	M6x1	0,260
mod. 12	301SF312	DXO/A 12	39	60	30	20	10	45	17	M6x45	Ø6x47x3	M6x1	0,290
mod. 14	301SF314	DXO/A 14	44	65	35	22,5	12	50	20	M8x50	Ø8x52x3,5	M6x1	0,420
mod. 16	301SF316	DXO/A 16	49	70	40	25	15	54	24	M8x55	Ø10x62x4	1/8G	0,560
mod. 18	301SF318	DXO/A 18	49	75	45	25	15	55	27	M8x55	Ø10x62x4	1/8G	0,670
mod. 20 22	301SF32022	DXO/A 20 22	54	80	50	27,5	15	60	32	M8x60	Ø12x72x4	1/8G	0,840
mod. 24 25 26	301SF3242526	DXO/A 24 25 26	64	95	55	32,5	17	75	35	M10x75	Ø14x82x4,5	1/8G	1,290
mod. 28 30 32	301SF3283032	DXO/A 28 30 32	69	100	60	35	20	80	40	M10x80	Ø14x92x4,5	1/8G	1,550
mod. 35 36	301SF33536	DXO/A 35 36	79	110	70	40	25	90	50	M10x90	Ø14x102x4,5	1/8G	2,180
mod. 40	301SF340	DXO/A 40	84	120	75	42,5	30	95	50	M12x100	Ø16x112x5	1/8G	2,590

– The supports above are shown assembled in the Excellent light (Groups (see preceding pages) for which it is possible to calculate the total weight by adding them to the weight of the TR screw using the table on page 165.

– To comply with safety regulations it is obligatory to use the locking tabs, the fitting hardware supplied, and ensuring that the arrows engraved in the supports are all facing in the same direction, which for vertical/oblique movements must be facing downwards.