

- **GROUP WITH LIGHTWEIGHT SUPPORTS OF REDUCED DIMENSIONS (without dust cups) for short movements.**
- **Use with single screw or double screw in parallel with single drive.**
- **Anodized aluminium alloy supports with antifriction resin bushes and cylindrical nylon nuts (POM.C Polyacetal) on trapezoidal screws.**

Group **C/DVO/A+LVZO** (first diagram on the side) is ideal for **fast movements of low loads** horizontally with short screw, allows the **regulation of axial play** but can, however, also be used vertically/obliquely after prior risk assessment relative to the specific application. The system allows the control of the maximum wear of the nuts, **tolerable up to a 1/4 of a pass** (see page 96), and helps to provide an adequate protection for the machine by limiting any eventual risks due to nuts breaking. For vertical use with **gearmotor** (or other) **above** the arrangement of the supports is in the sequence shown in the diagram. In particular cases in which the **gearmotor** (or other) is **positioned below the mobile supports** have to be **flipped 180°** with **LVO** above and **LZO** below and checking that the **arrows indicating the force of gravity are facing downwards**.

- **The guarantees of functionality and safety are determined by the proper use of the group together with perfect fitting on the machinery with the tabs inserted and the engraved arrows facing the same direction and, if used for vertical/oblique movements, they must face downwards.**
- The **C/DVO/A+LVO** Group (second diagram on the side) is only used for horizontal applications with short screw where axial play adjustment is not necessary.
- All of the Compact Groups can be purchased pre-assembled, with the supports inserted on the trapezoidal screw, in that for mounting on the Manoeuvring Unit requires no dismantling, fitting the Group to the machine as shown on the **Compact application diagram 2/A** on page 101.

Our Groups are ready for the fitting of accessories such as **gearmotors, handwheels, position indicators** and others and can be supplied by us, pre-selected according to the machined screw terminals and pre-fitted together with the supports that form the Group itself.

(Group ready for complementary accessories on page 265).

N.B. For vertical/oblique use where maximum safety is required consider the using the **Compact Safety** Group (see diagram on page 74).

For the correct use of this Group we also recommend reading the technical instructions on pages 105-107.

- **Indicative diagram of Manoeuvring Unit using “Compact Light LVZO” Group with “short” trapezoidal screw and axial play adjustment.**

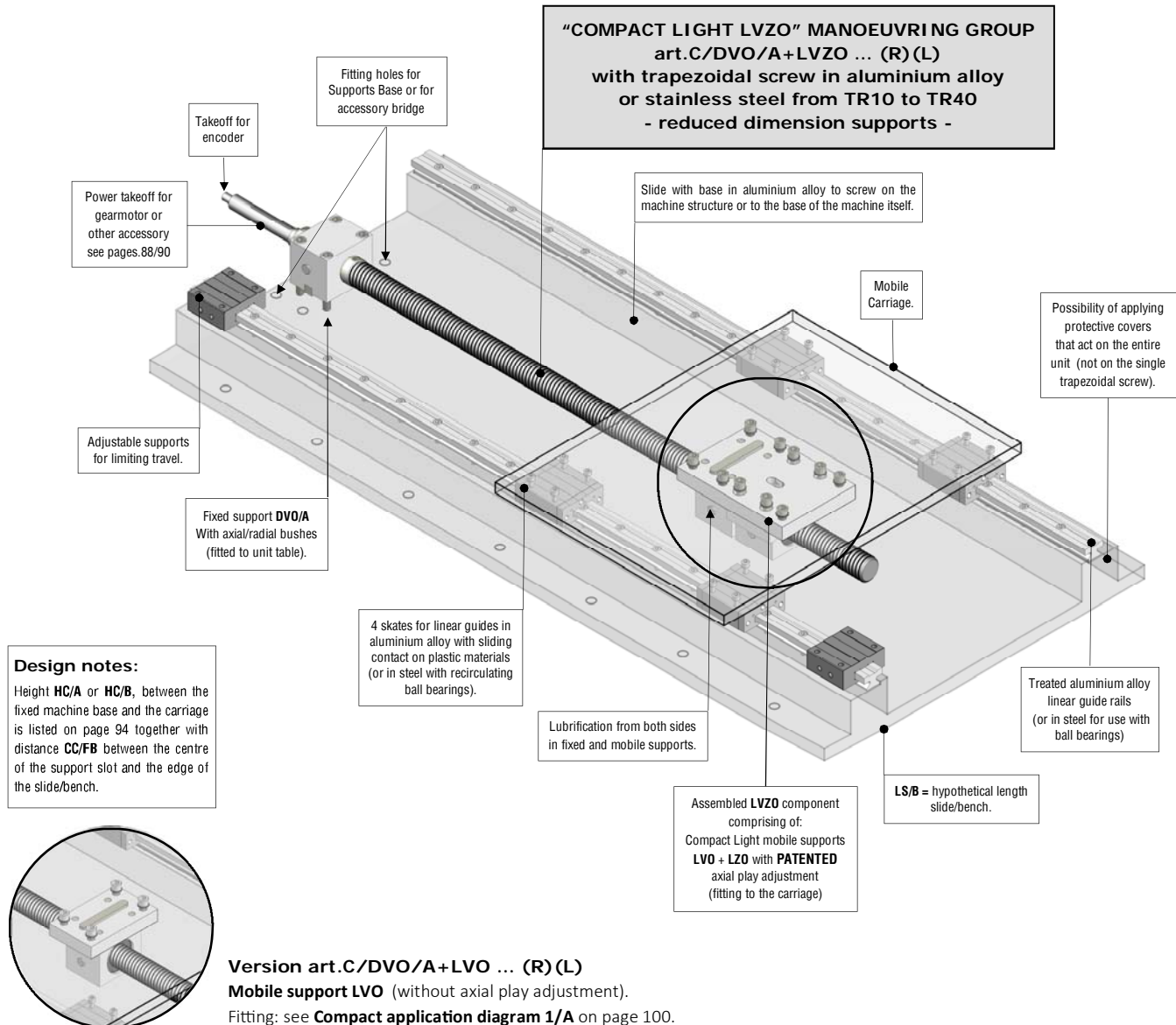

Group with right threaded components available from stock; with left threaded components made to order.

- **TRAPEZOIDAL SCREW MANOEUVRING GROUP mod. “COMPACT LIGHT”- art.C/DVO/A+LVZO ... (R)(L) series 10/40**
- Trapezoidal screw with maximum length of 25 times its diameter, double nut and ready for supports and accessories.

<p>COMPOSITION OF GROUP WITH THE RELATIVE SUPPORTS:</p> <ul style="list-style-type: none"> – Trapezoidal screw (type and length to be defined). – art.DVO/A Fixed support in aluminium alloy with resin bushes. 	<p>Assembled component LVZO on mobile Supports Base composed of:</p> <ul style="list-style-type: none"> – art.LVO Aluminium alloy mobile support with load bearing nut CCN/A. – art.LZO Adjustable aluminium alloy mobile support with nut CCN/A. 	<p>Fitting diagram of the Group on the slide “Compact Application 2/A” on page. 101 (or “2/B” with fixed supports on bases, same page)</p>
--	---	--

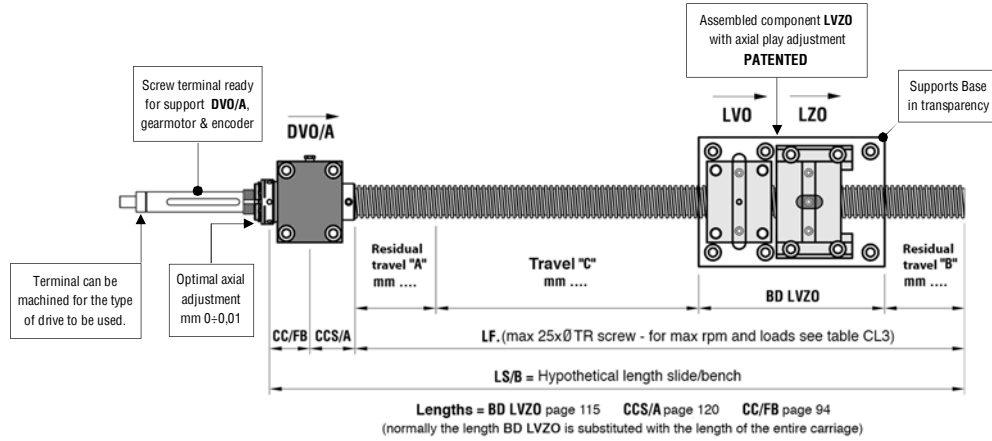

- **TRAPEZOIDAL SCREW MANOEUVRING GROUP mod. “COMPACT LIGHT”- art.C/DVO/A+LVO ... (R)(L) series 10/40**
- Trapezoidal screw with maximum length of 25 times its diameter, single nut and ready for supports and accessories.

<p>COMPOSITION OF GROUP WITH THE RELATIVE SUPPORTS:</p> <ul style="list-style-type: none"> – Same as above with the exclusion of Support art.LZO (group without axial play adjustment). 	<p>Fitting diagram of the Group on the slide “Compact Application 1/A” on page 100 (or “1/B” with fixed supports on bases same page)</p>
---	--

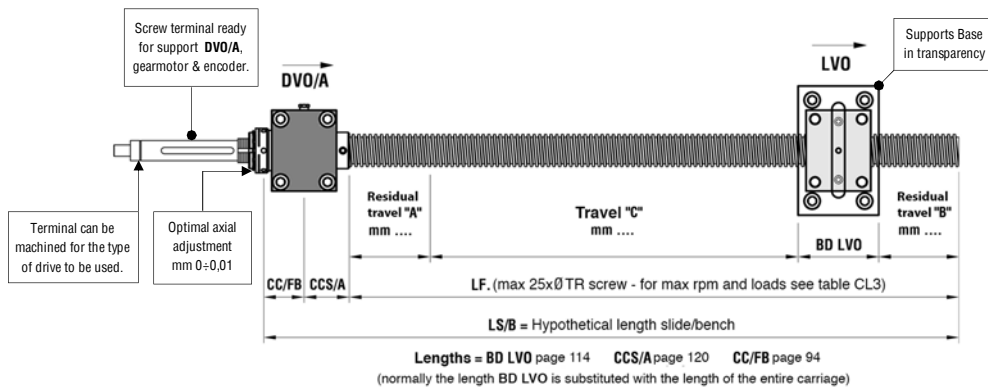

- **TRAPEZOIDAL SCREW DESIGN of threaded bar ready for the above supports, gearmotor (positioned at the side or above) & encoder.** For positioning the gearmotor below (for use only in cases of extreme necessity) please ask for the appropriate screw. Trapezoidal screw terminal: for specific details please see pages 88/90, for general details please see pages 48 - 56.

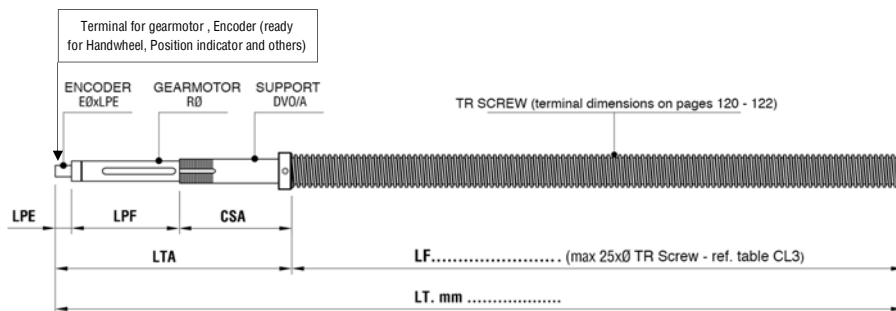

- For sizing the Manoeuvring Group screw and consequent gearmotor, consult our tables CL3/CL4 on pages 120 - 123 with subsequent compilation of this page quoting the Group in the points indicating “Travel A – Travel B – Travel C” together with the Questionnaire found on pages 64-65.
- Please send everything to our technical department for optimizing. For the dimensions of single supports and spare parts please see the following pages.