

# Retaze pre zavesne dopravniky

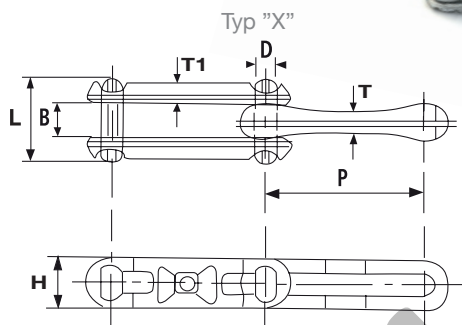

## Kovane retaze

Referencia	Rozostup	Vnutorna sirka	ø Cap		Rozmer platniciek		Sila pretrhnutia	Hmotnost / meter
			ø	Dlžka	Sirka	Hrubka		
	P	B	D	L	H	T/T1	Q min	q
	mm	mm	mm	mm	mm	mm	KN	Kg/m
X348	76,6	18,8	12,7	44,0	28	13,0/10,4	110	3,3
X458	102,4	25,0	15,8	57,0	36	16,0/12,0	220	4,8
4"	101,6	25,0	15,8	57,0	36	16,0/12,0	220	4,8
CC-100	100,8	25,0	15,8	57,0	36	16,0/12,0	220	4,8
468	102,4	40,9	19,1	81,0	48	29,0/16,0	320	11,2
X658	153,2	25,0	15,8	57,0	36	16,0/12,0	220	3,9
X678	153,2	32,5	22,2	77,0	51	20,6/18,0	380	10,0
698	153,2	39,1	28,4	98,0	64	25,4/22,2	605	17,0
160	160	32,5	22,2	77,0	51	20,6/18,0	380	10,0
998	229,4	39,1	28,4	98,0	64	25,4/22,2	605	13,4

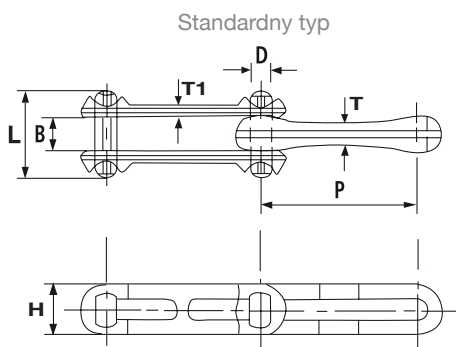
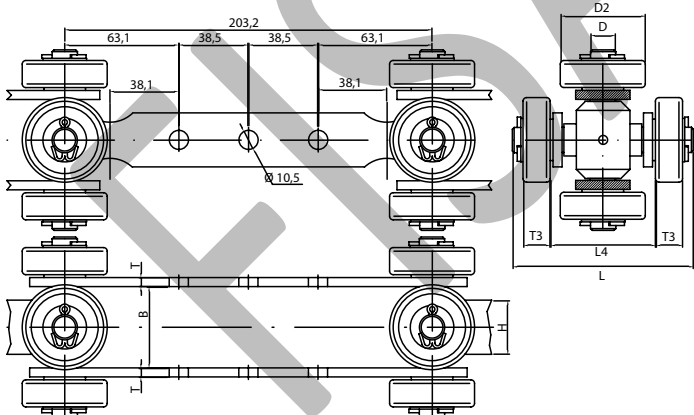

## Prevedenie s kryzom a loziskami

Rozostup	Vnutorna sirka	ø Cap	ø Lozisko	Sirka platniciek	Hrubka platniciek	Dlžka capu	Sirka loziska	Sirka medzi loziskami
P	B	D	D2	H	T	L	T3	L4
mm	mm	mm	mm	mm	mm	mm	mm	mm
203,2	30	10	37	25	4	78	13	44
203,2	45	14	47	30	5	98	15	59