

Redlerove dopravne retaze

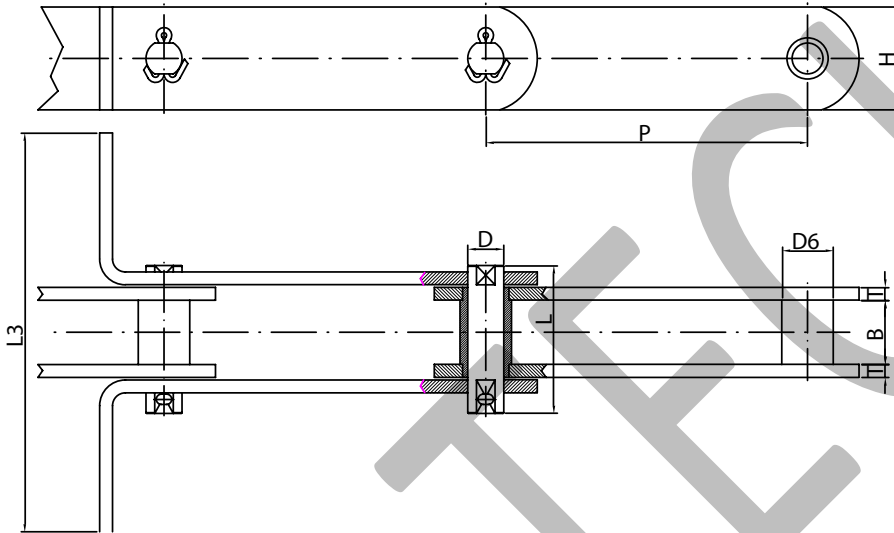

Rozostup	Vnutorna sirka	ø Puzdro	Cap		Platnicky		Skrabak	Sila pretrhnutia
			ø	Dlžka	Sirka	Hrubka		
P	B min	D6	D	L max	H	T	L3 min	Q min
mm	mm	mm	mm	mm	mm	mm	mm	KN
100	20	17	12	43	35	4	140	91,2
125	20	17	12	43	35	4	140	91,2
100	22	18	12	44,5	30	4	140	67,2
125	22	18	12	44,5	30	4	140	67,2
100	25	20	14	52	40	5	140	132,0
125	25	20	14	52	40	5	180	132,0
150	25	20	14	52	40	5	180	132,0
100	30	22	16	61	40	6	180	144
125	30	22	16	61	40	6	180	144
150	30	22	16	61	40	6	180	144
200	30	22	16	61	40	6	180	144
125	35	26	18	67	50	6	200	187,2
150	35	26	18	67	50	6	240	187,2
200	35	26	18	67	50	6	240	187,2
150	45	30	20	85	50	8	280	211,2
200	45	30	20	85	50	8	280	211,2

* Možnosť výroby aj iných rozmerov

Možnosť vyhotovenia s nitovanými a oddeliteľnými skrabakmi na jednej alebo oboch stranách.