

Pružná spojka v hliníkovom prevedení Al-H, typ A

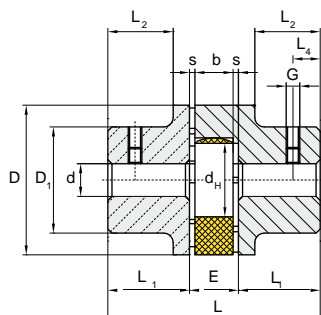

Kombinácia nábojov A/A

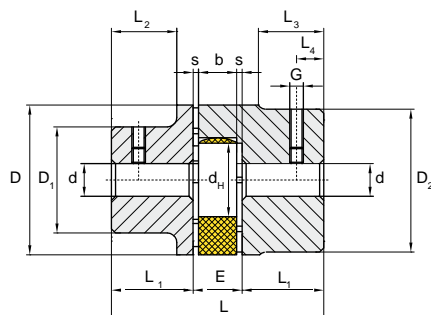

Kombinácia nábojov A/B

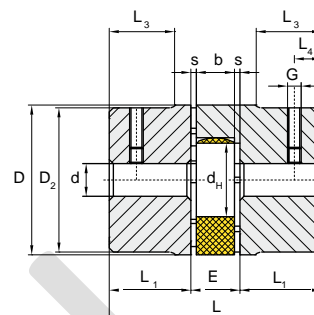

Kombinácia nábojov B/B

Typ spojky A	Diery v nábojoch				Rozmery [mm]													
	Naboj A		Naboj B		Ø D	Ø D ₁	Ø D ₂	L	L ₁	E	s	b	L ₂	L ₃	Ø d _H	G	L ₄	
	Ø d [mm]	min.	max.	Ø d [mm]														min.
Veľkosť	14	-	-	-	16	30	-	30	35	11	13	1,5	10	-	-	10	M4	5
	19	6	19	6	24	40	32	40	66	25	16	2	12	20	-	18	M5	10
	24	8	24	8	32	55	40	55	78	30	18	2	14	24	-	27	M5	10
	28	10	28	10	38	65	45	65	90	35	20	2,5	15	28	-	30	M6	15
	38	12	38	12	45	80	66	77	114	45	24	3	18	37	37	38	M8	15

- vyrobené z jedného kusa hliníka Al-H
- torzne flexibilné, bezúdržbové spojenie absorbujúce vibrácie
- axiálne nasúvacie, bezpečné spojenie
- rôzne tvrdosti pružného elementu

Príklad objednávky:

A 28	92°	A	Ø 12 H7	4 P9	B	Ø 25 H7	8 P9
Typ spojky	Tvrdosť pružného elementu	Naboj A	Vŕtanie nahotov	Perodrážka	Naboj B	Vŕtanie nahotov	Perodrážka

Pružná spojka v hliníkovom prevedení Al-H, typ A-KN

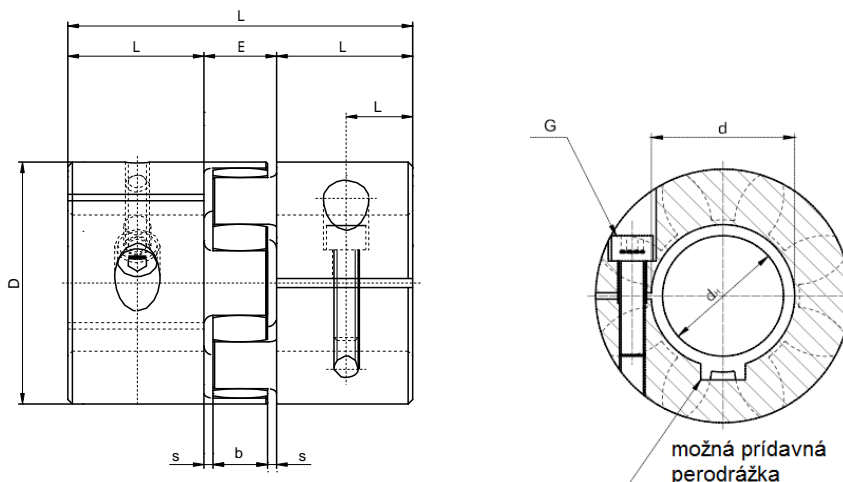

Typ A-KN	Diery v nábojoch		Rozmery [mm]									
	min. Ø d [mm]	max. Ø d [mm]	Ø D	L	L ₁	L ₂	L ₃	E	s	b	Ø d _H	ISO 4762 G
19	6	24	40	66	25	13	-	16	2	12	18	M6x16
24	8	28	55	78	30	18	-	18	2	14	27	M6x20
28	10	38	65	90	35	21	-	20	2,5	15	30	M8x25
38	12	45	80	114	45	26	-	24	3	18	38	M8x30

Prenášané momenty závisia od veľkosti diery.

Vyhotovenia spojky:



Vyhotovenie 0 =
diera v spojke bez
perodrážky



Vyhotovenie 1 =
diera v spojke s
perodrážkou

Príklad objednávky:

A-KN A 28	92°	0	Ø 30	1	Ø 25
Typ spojky	Tvrdosť pružného elementu (*Sh)	Prevedenie	Diera	Prevedenie	Diera

Pružná spojka v hliníkovom prevedení Al-H, typ A-AK

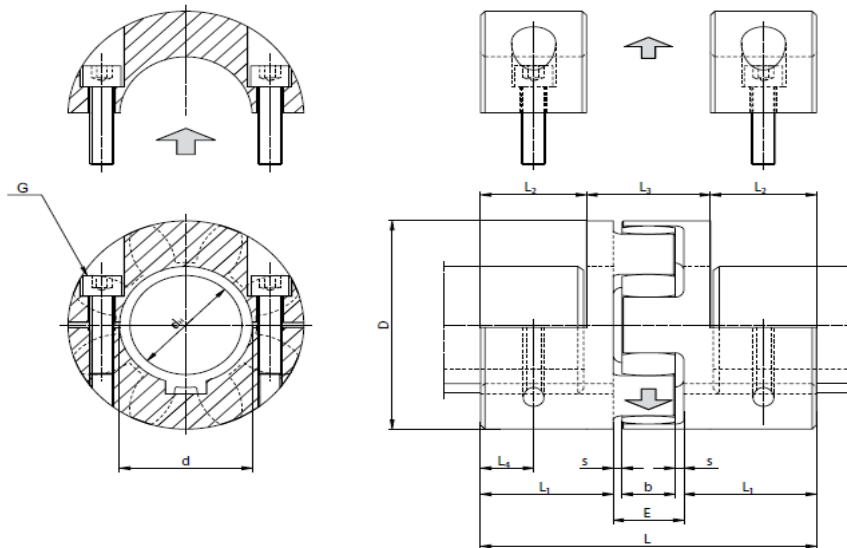

A-AK Typ	Vŕtanie ¹⁾		Rozmery [mm]											
	min. Ø d [mm]	max. Ø d [mm]	Ø D	L	L ₁	L ₂	L ₃	E	s	b	Ø d _H	ISO 4762 M x l	G	L ₄
19	6	24	40	66	25	18	30	16	2	12	18	M6x16	G	9
24	8	28	55	78	30	23	32	18	2	14	27	M6x20	G	11,5
28	10	38	65	90	35	26	38	20	2,5	15	30	M8x25	G	13
38	12	45	80	114	45	36	42	24	3	18	38	M8x30	G	18

¹⁾ vŕtanie H7 a perodrážka podľa DIN 6885-1

Príklad objednávky:

A-AK	92°	Ø 25	P9	Ø 30	P9
Typ spojky	Tvrdosť pružného elementu (°Sh)	Vŕtanie	Perodrážka	Vŕtanie	Perodrážka