

PE vedenie remenov

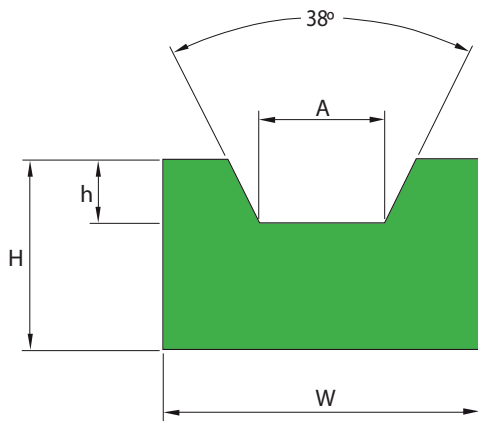

Ref.	W	H	h	A	Kg/m
YCT 10Z	20	10	3	6,5	0,197
YCT 13A	20	12	5	8	0,232
YCT 15E	25	12	5	10	0,292
YCT 17B	30	15	8	10,5	0,429
YCT 22C	35	20	11	13,5	0,660
YCT 30D	40	25	13	19	0,944

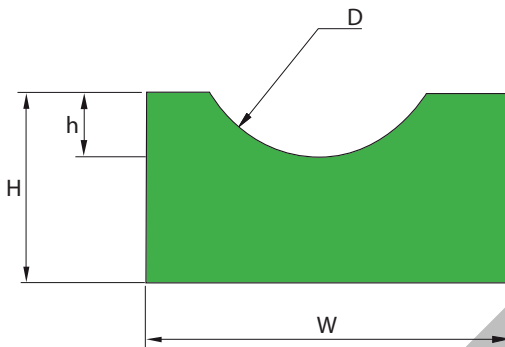

Ref.	D	W	H	h	Kg/m
YCOR-04	4	15	10	2	0,144
YCOR-05	5	15	10	2,5	0,140
YCOR-06	6	20	10	3	0,186
YCOR-08	8	20	10	4	0,175
YCOR-10	10	25	12	5	0,260
YCOR-12	12	25	12	6	0,244
YCOR-15	15	25	15	7,5	0,286
YCOR-20	20	30	20	10	0,442

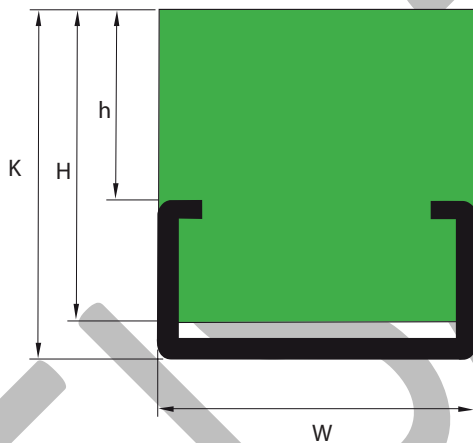

Ref.	W	K	H	h	Profil	Kg/m
YHCG-2006	20	6	5	0,8	C2405	0,350
YHCG-2010	20	14	10	4	C2010	0,790
YHCG-2015	20	17	15	7	C2010	0,880
YHCG-2020	20	22	20	12	C2010	0,940
YHCG-2810	28	15	10	3	C2812	1,180
YHCG-2815	28	18	15	6	C2812	1,320
YHCG-2820	28	24	20	12	C2812	1,480
YHCG-3812	38	22	12	4	C3818	2,200
YHCG-3815	38	24	15	6	C3818	2,460
YHCG-3820	38	30	20	12	C3818	2,690
YHCG-6020	60	30	20	10	C6020	3,260

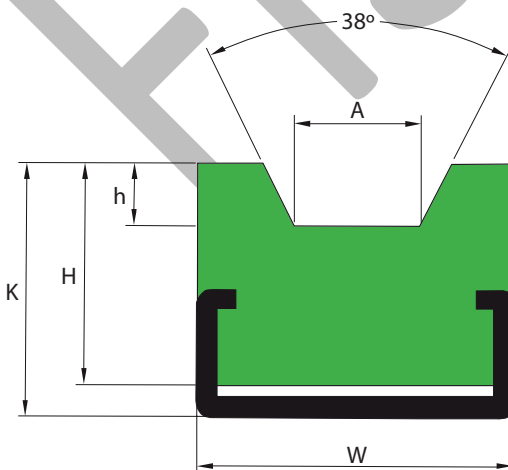

Ref.	W	H	h	K	A	Profil	Kg/m
YCTCG 10Z	20	15	3	17	6,5	C2010	0,787
YCTCG 13A	20	15	5	17	8	C2010	0,787
YCTCG 15E	25	20	5	24	10	C2812	1,352
YCTCG 17B	30	20	8	24	10,5	C2812	1,439
YCTCG 22C	38	25	11	32	13,5	C3818	2,265
YCTCG 30D	40	30	13	35	19	C3818	2,574

PE vedenie remenov

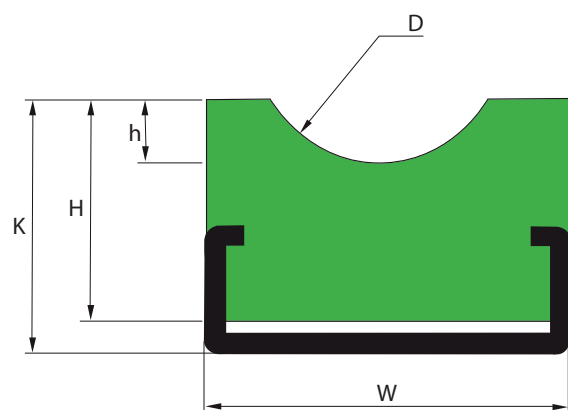

Ref.	D	W	H	h	K	Profil	Kg/m
YCORCG 04	4	20	10	2	14	C2010	0,680
YCORCG 05	5	20	10	2,5	14	C2010	0,675
YCORCG 06	6	20	10	3	14	C2010	0,660
YCORCG 08	8	20	10	4	14	C2010	0,650
YCORCG 10	10	28	15	5	18	C2812	1,179
YCORCG 12	12	28	15	6	18	C2812	1,140
YCORCG 15	15	28	15	7,5	18	C2812	1,160
YCORCG 20	20	28	20	10	24	C2812	1,280

YMC Profil 2020 Typ

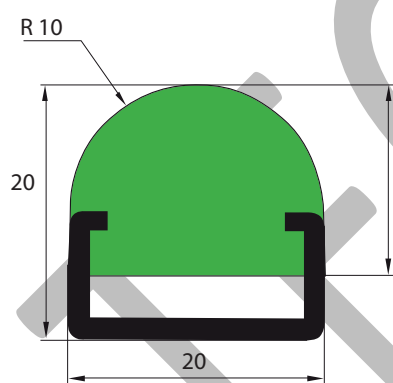

Vedenia pre ploche remene

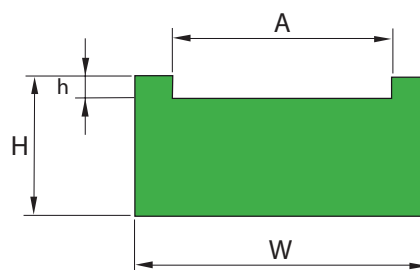
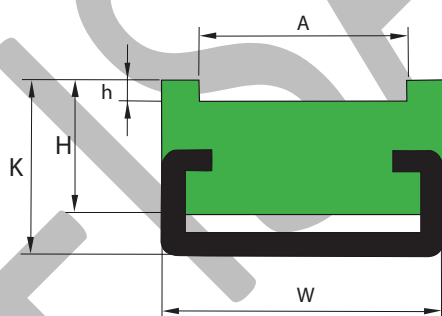

Moznosť dodania v nerezovom alebo pozinkovanom prevedení.

Standardná dĺžka 2 metre.