

DA – obmedzovač krútiaceho momentu s reťazovým diskom

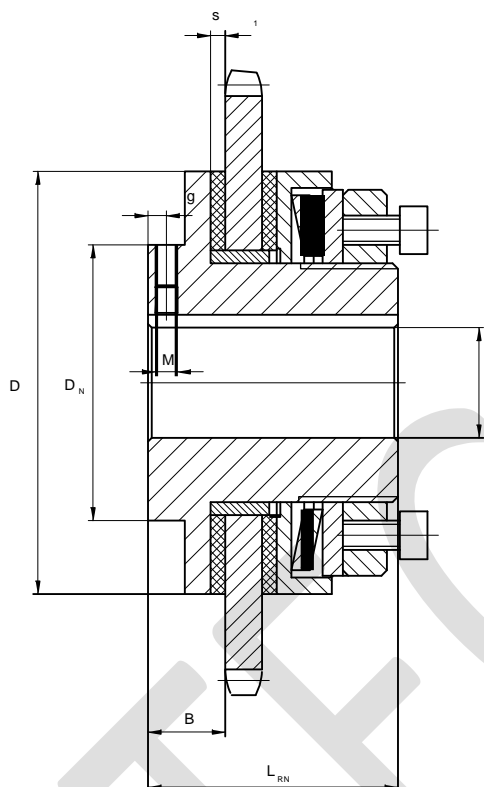

Veľkosť	max. otáčky [1-min]	Krútiaci moment [Nm]			Rozmery [mm]								
		1 TF	2 TF	3 TF ¹⁾	Diera d2		D	D _N	B	s ₁	L _{RN}	Fixačné skrutky	
					Predvrtanie	Diera max.						g	M
00	10000	0,5–5	1–10	–	4,8	10	30	30	8,5	2,5	31	3	M4
0	8500	2–10	4–20	–	5,7	20	45	45	8,5	2,5	33	3	M4
01	6600	5–35	10–70	60–105	10	22	58	40	16	3	45	4	M5
1	5600	20–75	40–150	130–200	10	25	68	45	17	3	52	6	M5
2	4300	25–140	50–280	250–400	14	35	88	58	19	3	57	6	M6
3	3300	50–300	100–600	550–800	18	45	115	75	21	4	68	6	M6
4	2700	90–600	180–1200	1100–1600	24	55	140	90	23	4	78	6	M8
5	2200	280–800	800–1600	1400–2100	28	65	170	102	29	5	92	8	M8
6	1900	300–1200	600–2400	–	38	80	200	120	31	5	102	8	M6
7	1600	600–2200	1200–4400	–	45	100	240	150	33	5	113	8	M10
8	1300	900–3400	1800–6800	–	58	120	285	180	35	5	115	8	M10

¹⁾ Hrúbka pohybovaného dielu redukovaná

Príklad objednávky:

DA	1	2 TF	08 B1, z = 20	Ø 20	6 P9
Typ	Veľkosť	Označenie pružiny	Reť. koleso	Diera	Perodrážka