

# Ekonomicke klby seria AL

Jednoduche max.  $\alpha$  45° - Dvojite max.  $\alpha$  90°

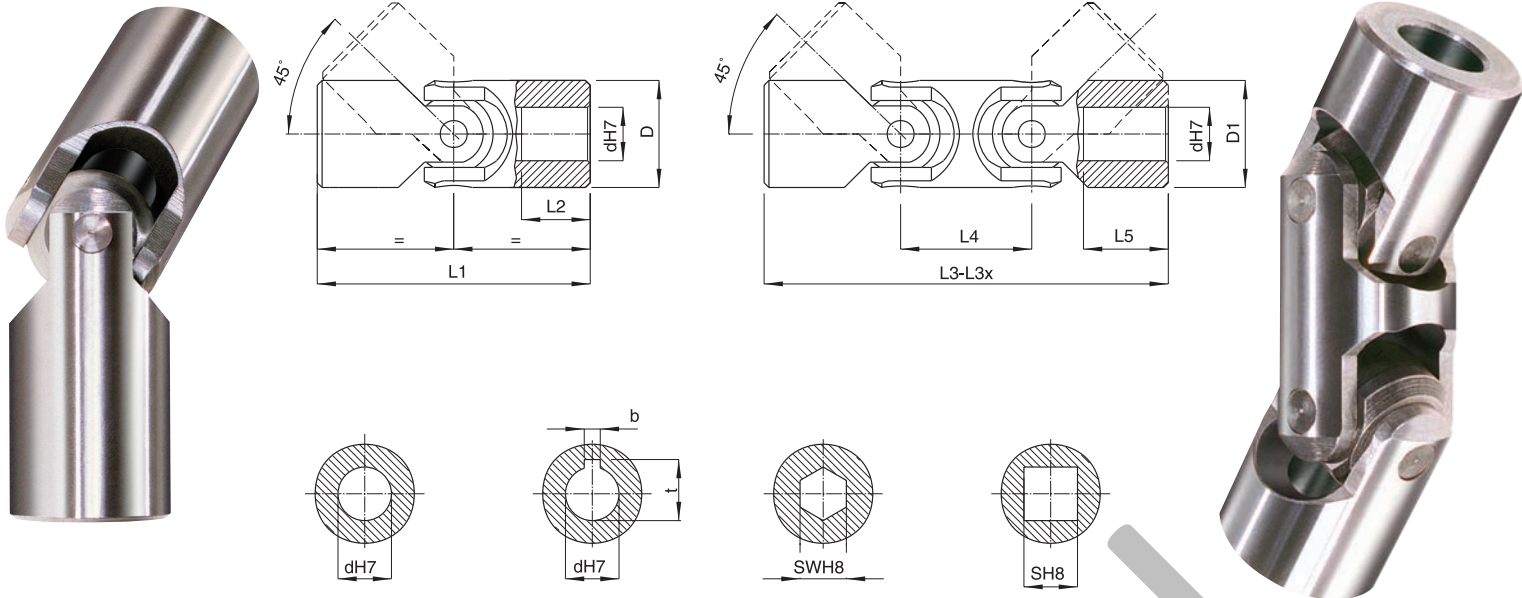

Ekonomicke vyhotovenie klbov najde vyuzitie u strednych a malych rychlosti a obmedzenym Mk.

JEDNODUCHE KLBY					MOZNE VRTANIE						DVOJITE KLBY						MOZNE VRTANIE						
TYP	dh7	D	L1	L2	dh7	D	L1	L2	L1X	L2X	TYP	dh7	D1	L3	L3x	L4	L5	dh7	b	t	SH8	SWH8	
100	5	10	40	13	-	-	-	-	-	-	-	-	-	-	-	-	-	-	-	-	-	-	5
101AL	6	13	40	13	-	-	-	-	-	-	101ADL	6	13	63	-	23	13	-	-	-	6	-	
102AL	8	16	40	10	-	-	-	-	-	-	102ADL	8	16	67	-	27	10	-	2	9	8	8	
103AL	10	20	45	10	12	22	50	12	48	62	103ADL	10	20	74	-	29	10	12	3	11,4	10	10	
104AL	12	25	50	11	14	25	56	14	56	74	104ADL	12	22	74	86	29	11	16	4	13,8	12	12	
105AL	14	29	56	13	16	29	65	17	60	74	105ADL	14	25	85	95	33	13	-	5	16,3	14	14	
106AL	16	32	65	15	18	32	72	18	68	86	106ADL	16	29	100	104	35	19	20	5	18,3	16	16	
107AL	18	37	72	17	20	37	82	22	74	-	107ADL	18	32	112	114	39	20	-	6	20,8	18	18	
108AL	20	40	82	19	22	40	95	25	108	-	108ADL	20	40	128	127	46	19	25	6	22,8	20	20	
109AL	22	47	95	22	25	45	108	28	-	-	109ADL	22	40	145	-	46	25	-	6	24,8	22	22	
110AL	25	50	108	27	30	50	122	34	105	132	110ADL	25	50	163	-	59	24	-	8	28,3	25	25	
111AL	30	58	122	30	35	58	140	39	166	-	111ADL	30	58	182	-	66	30	-	8	33,3	30	30	

L1X, L2X, L3X uprava dlzok na zaklade dopytu

TYP	Otacky / min.							
	100	200	300	400	500	700	800	
-	100	5,5	4,2	3,8	3,5	-	-	
-	100AL	6,6	6,6	5,3	4,8	4,4	-	
-	102AL	13	9	8	7	6	5,2	
125AL	103AL	25	17	15	12	11	10	
126AL	104AL	45	25	21	16	14	11	
127AL	105AL	70	45	40	33	30	26	
128AL	106AL	88	85	72	55	50	43	
129AL	107AL	160	120	100	68	58	54	
130AL	108AL	240	170	120	90	80	72	
131AL	109AL	300	200	150	110	93	-	
132AL	110AL	390	250	180	140	115	-	
133AL	111AL	430	330	200	150	128	-	

PRAC. UHOL $\alpha$	FAKTOR F
5°	1,25
10°	1
20°	0,75
30°	0,45
40°	0,30
45°	0,25

Pre dvojite klbove hriadele je vykon 90% z uvedenych momentov

# Ekonomické klby seria AL s rychlospojkou

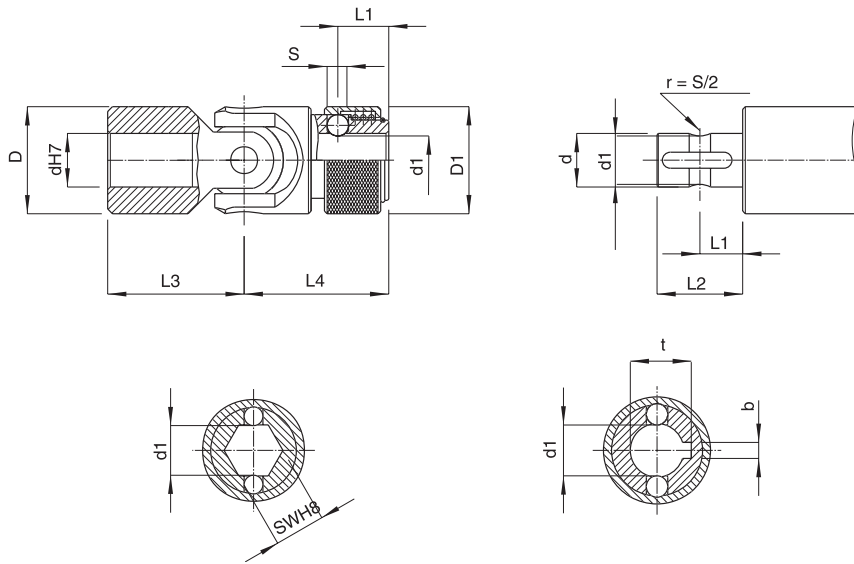

TYP	d	D1	I1	I2	I3	I4	S	SW	d1	bxt
103ALR	10	20	11,5	17	22,5	31	4	10	8,7	3x11,2
104ALR	12	25	13,5	21	25	37	4	12	11	4x13,3
105ALR	14	29	13,5	21	28	37	4	14	13	5x15,3
106ALR	16	32	14	25	32,5	43	6,3	16	14,8	5x17,3
107ALR	18	37	19	33	36	50	8	18	16	6x19,8
108ALR	20	40	19	33	41	54	8	20	18	6x21,8
109ALR	22	47	20,5	38	47,5	60	10	22	20	6x23,8
110ALR	25	50	20,5	38	54	66	10	25	23	8x26,8
111ALR	30	58	25	50	61	83	10	30	28	8x32,2

TYP	Otacky / min.							
	100	200	300	400	500	700	800	
125AL	103ALR	25	17	15	12	11	10	7
126AL	104ALR	45	25	21	16	14	11	9
127AL	105ALR	70	45	40	33	30	26	22
128AL	106ALR	88	85	72	55	50	43	34
129AL	107ALR	160	120	100	68	58	54	-
130AL	108ALR	240	170	120	90	80	72	-
131AL	109ALR	300	200	150	110	93	-	-
132AL	110ALR	390	250	180	140	115	-	-
133AL	111ALR	430	330	200	150	128	-	-

PRAC. UHOL $\alpha$	FAKTOR F
5°	1,25
10°	1
20°	0,75
30°	0,45
40°	0,30
45°	0,25

# Ekonomicke klby seria AL vysuvne prevedenie

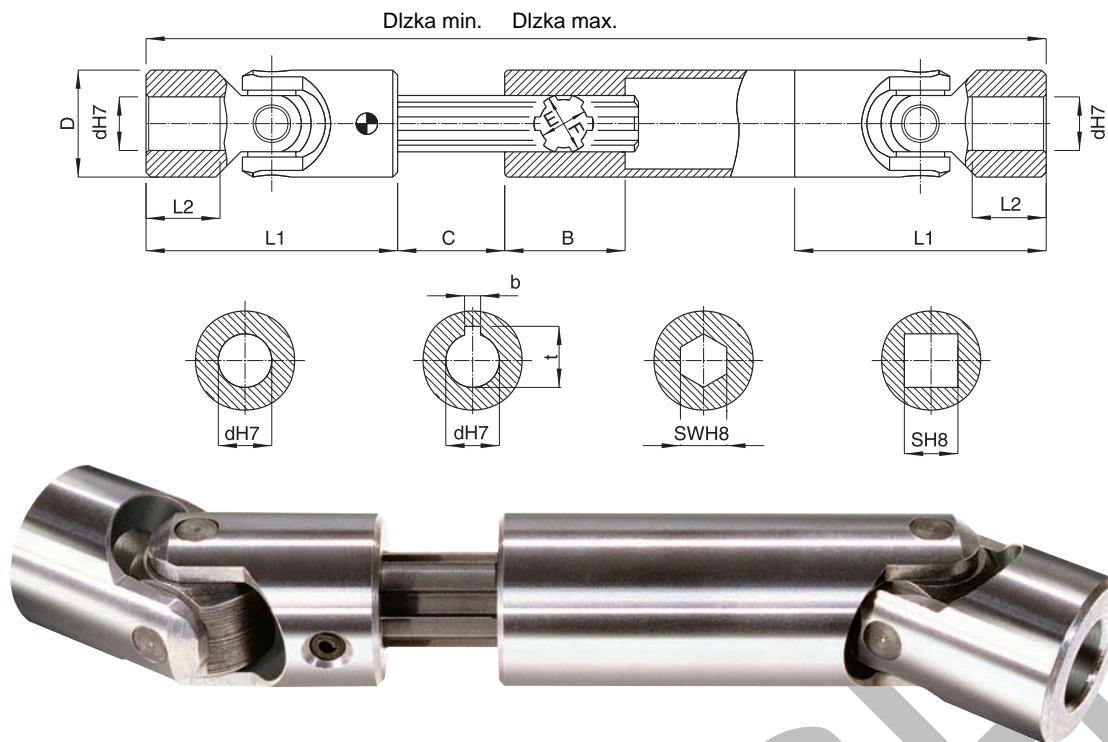

"L" dlzka na zaklade dopytu  
 $\min L = (2 \times L1) + B + C$   
 $\max L = (2 \times L1) + B + (2 \times C)$   
 $C = \max L - \min L$

Standardne prevedenie je s okruhou dierou  
 Perodrazky - Stvorec - Sestuholnik na zaklade dopytu  
 Drazkovany hriadel je standardne dodany ako tahany profil  
 Moznost dodat ako frezovany - kaleny - bruseny

TYP	d	D	I1	I2	B	E/F	s	sw	bxt
125AL	10	22	45	10	40	11/14	10	10	3x11,4
126AL	12	25	50	11	45	13/16	12	12	4x13,8
127AL	14	29	56	13	45	13/16	14	14	5x16,3
128AL	16	32	65	15	45	16/20	16	16	5x18,3
129AL	18	37	72	17	45	16/20	18	18	6x20,8
130AL	20	40	82	19	45	18/22	20	20	6x22,8
131AL	22	47	95	22	48	21/25	22	22	6x24,8
132AL	25	50	108	27	48	23/28	25	25	8x28,3
133AL	30	58	122	30	50	26/32	30	30	8x33,8

TYP	Otacky / min.							
	100	200	300	400	500	700	800	
125AL	103ALR	25	17	15	12	11	10	7
126AL	104ALR	45	25	21	16	14	11	9
127AL	105ALR	70	45	40	33	30	26	22
128AL	106ALR	88	85	72	55	50	43	34
129AL	107ALR	160	120	100	68	58	54	-
130AL	108ALR	240	170	120	90	80	72	-
131AL	109ALR	300	200	150	110	93	-	-
132AL	110ALR	390	250	180	140	115	-	-
133AL	111ALR	430	330	200	150	128	-	-

Pre dvojite klbove hriadele je vykon 90% z uvedenych momentov

PRAC. UHOL $\alpha$	FAKTOR F
5°	1,25
10°	1
20°	0,75
30°	0,45
40°	0,30
45°	0,25