

# SA

## AUTOMATIC GREASERS

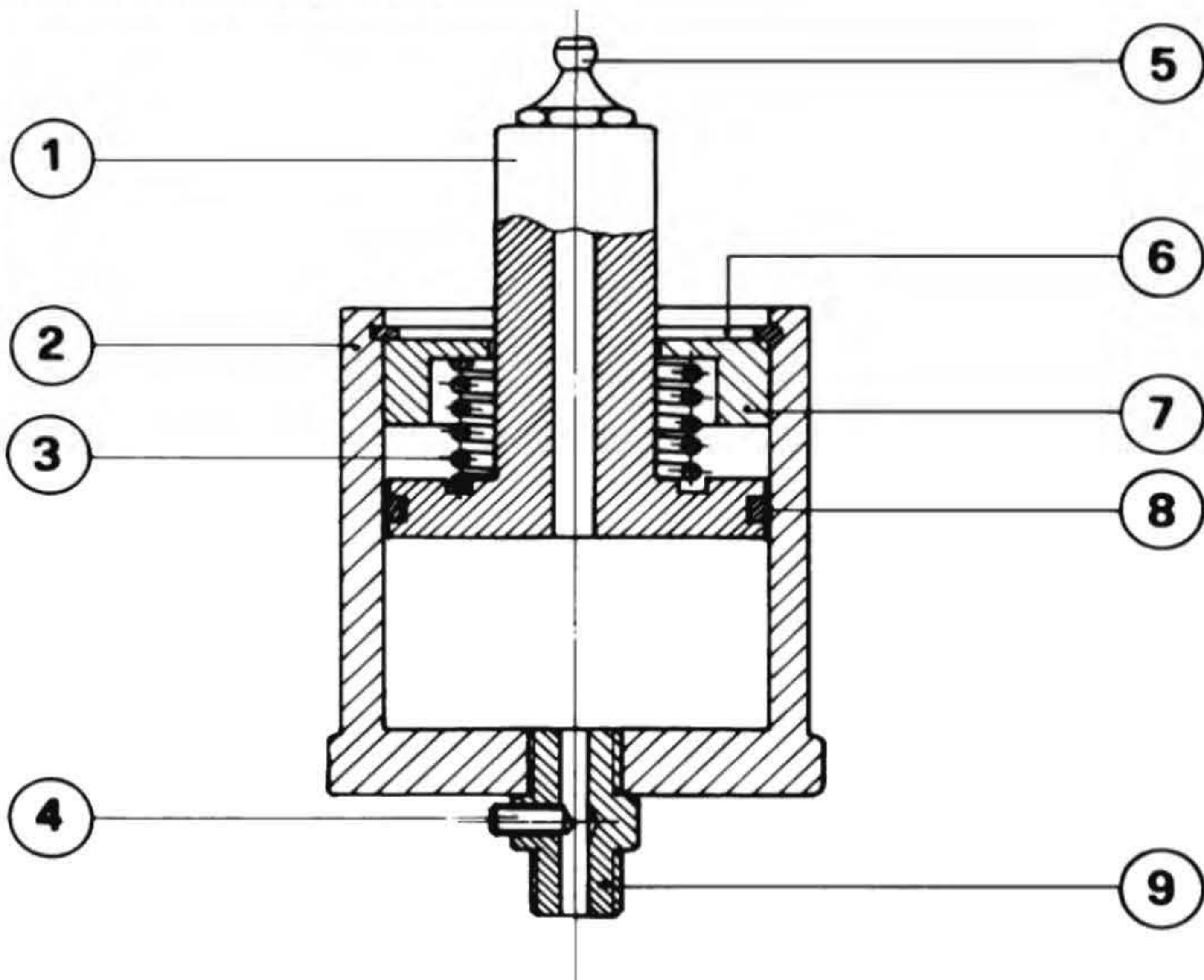

**AT LAST YOU CAN SOLVE A LOT OF MAINTENANCE PROBLEMS WITH SA AUTOMATIC GREASERS!**  
**Easy, straightforward installation,**  
**Constant and adjustable grease feed,**  
**Small size**  
**Made out entirely of light alloy,**  
**Possibility of high temperature operation,**  
**No more stoppages due to lack of lubrication**  
**Fewer maintenance operations**  
**Considerable cost saving.**



DESCRIPTION
1 Piston
2 External Body
3 Spring
4 Grease dispenser
5 Filling Head
6 Snap Ring
7 Spacer
8 O-Ring
9 Linkage

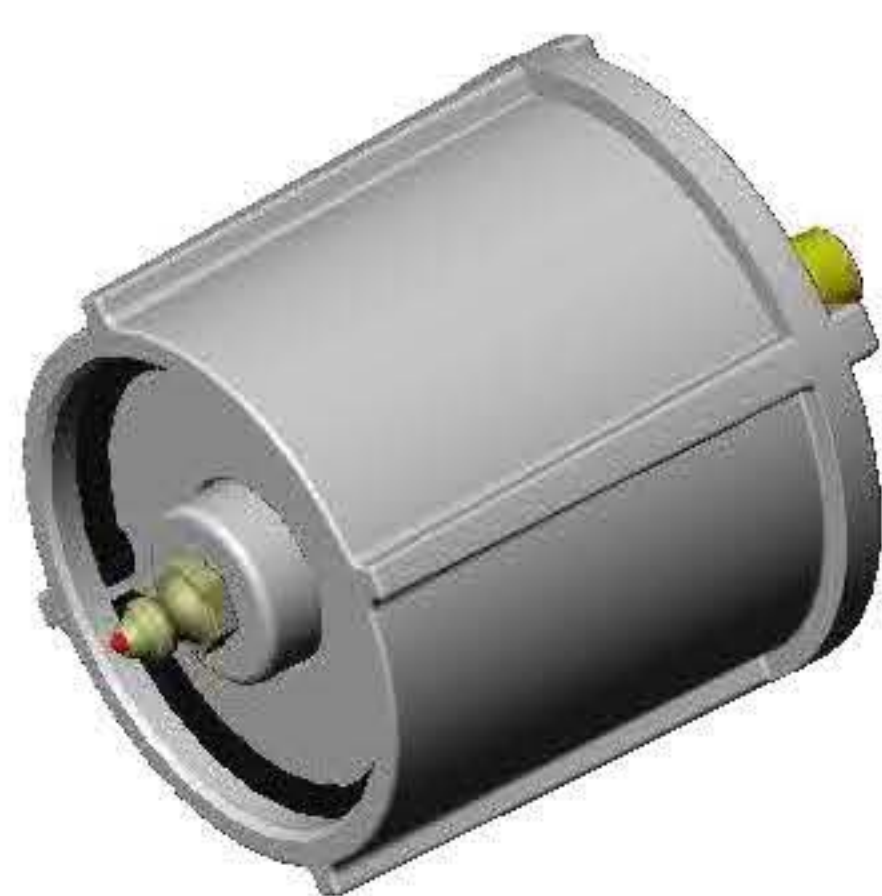

**N.B.**  
The quantity of the grease that comes out depends on:  
a) the type of device to lubricate  
b) the operating temperature  
c) the number of turn  
d) the viscosity of the grease used  
e) the frequency of intervention  
f) the load applied

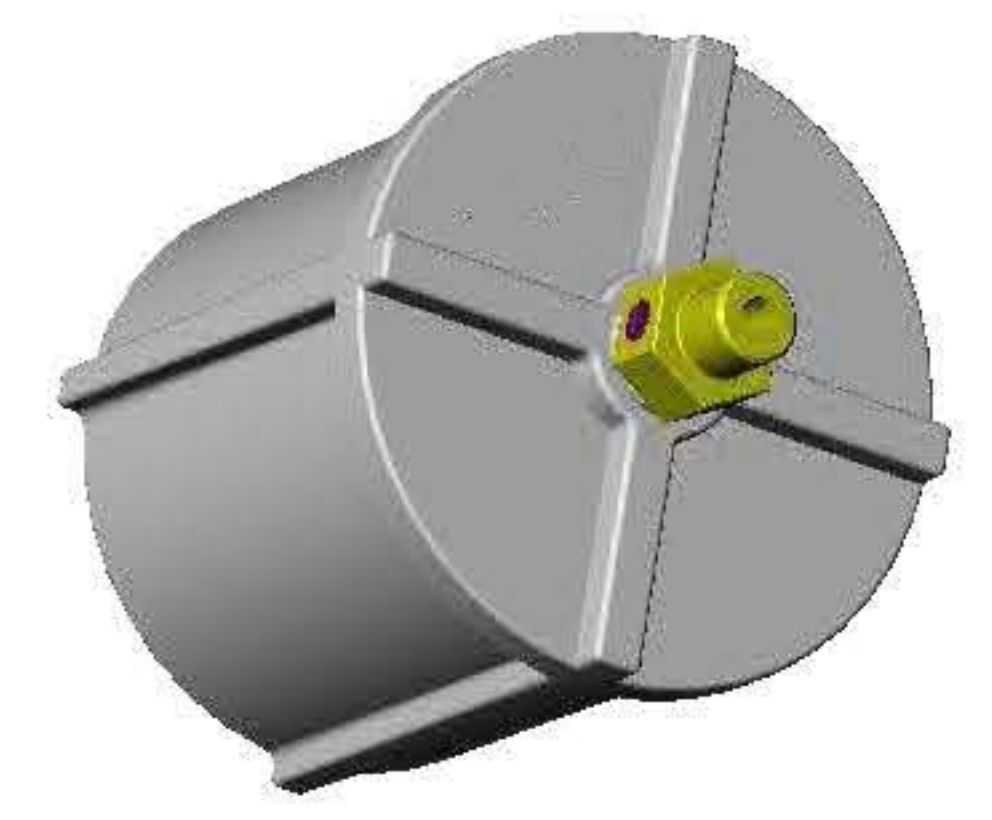





# SA

## AUTOMATIC GREASERS

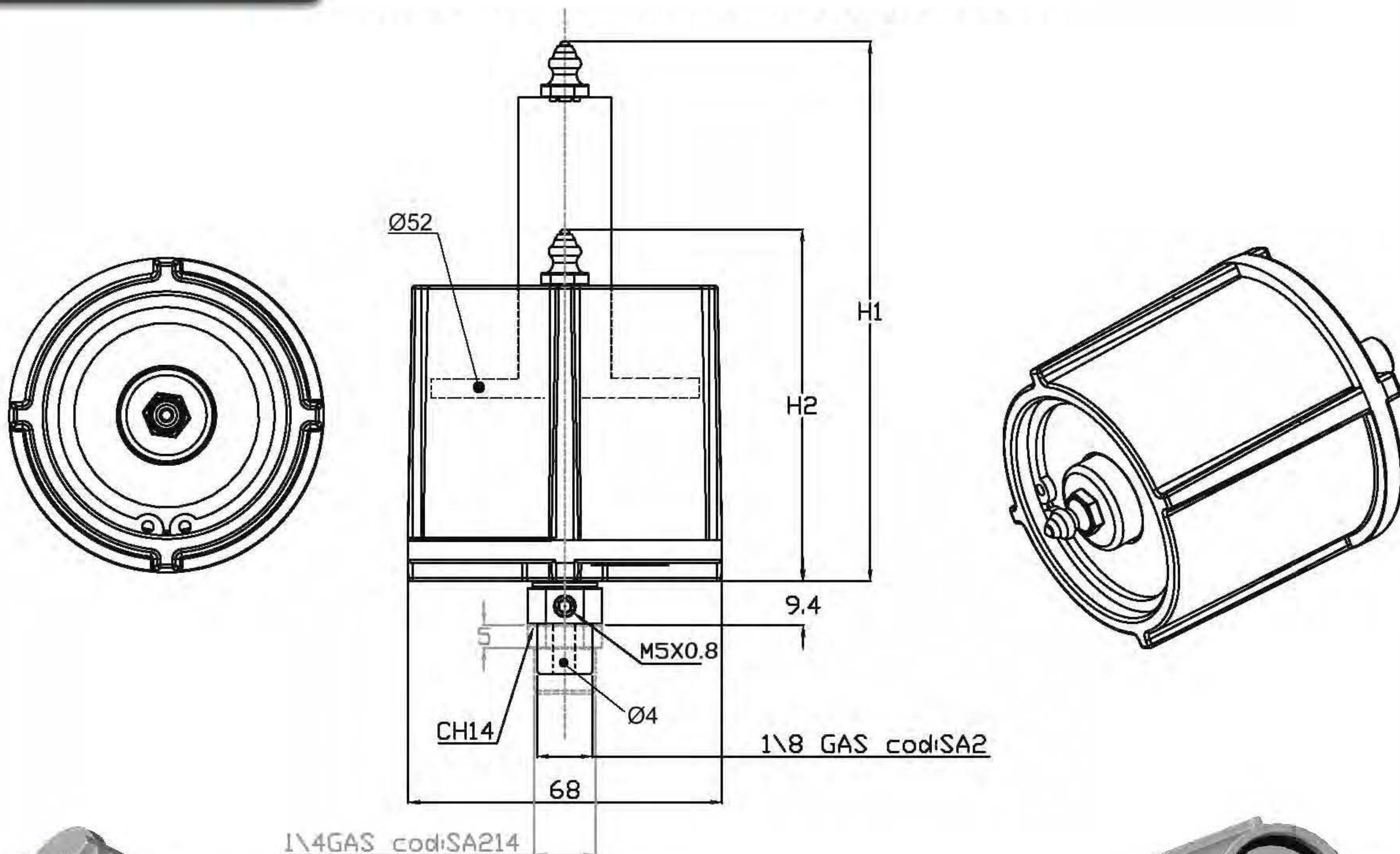

COD	CAPACITY	FULL	EMPTY	Kg
	CC	H1	H2	
SA2	CC 65	106	75	0,312
SA214	CC 65	106	75	0,314

### SETTING OF THE DISPENSER

If you act on the screw with the embedded hexagon that is set up on the threaded nipple 1/8"GAS you can determine the quantity of grease that comes out of the greaser:

If you turn the screw in you cut down the grease that comes out

If you unscrew you increase the quantity of grease that comes out.